

Pin	Signal	Mating Sequence
A5	CC1	Second
A9	V _{bus}	First
A12	GND	First
B5	CC2	Second
B9	V _{bus}	First
B12	GND	First
SHELL	GND	

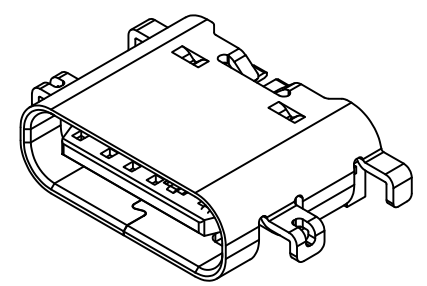

Specifications

Material

Insulator: LCP, E130i, UL 94V-0, Black
 Contact: Copper Alloy, C2680
 Shell: Stainless steel, SUS201
 Mid Plate: Stainless Steel, SUS301

Plating

Terminal:
 Contact Area: Gold Flash
 Solder Tails: 50µ" min. Matte Tin
 Underplating: 50µ" Min. Nickel Over All
 Shell: 50µ" min. Nickel
 Mid Plate: Clear

Electrical

Current Rating: 3.00A collectively for V_{bus} pins
 4.25A collectively for GND pins
 1.25A for A5/B5 pin
Voltage Rating: 48V DC
Contact Resistance: 40mΩ max initial.
 50mΩ max after test
Dielectric Withstanding Voltage: 100V AC
Insulation Resistance 100MΩ min

Mechanical & Environmental

Operating Temperature: -30°C to +85°C
Mating Force: 5 to 20 N.
Unmated Force: 6 to 20 N after test
Durability: 20,000 cycles

Recommended PCB Layout

Thickness=0.80mm
 As viewed from component side Tolerance:±0.05mm
 Solder Area Component Outline

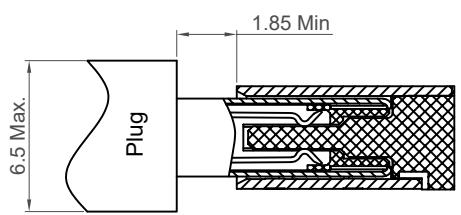
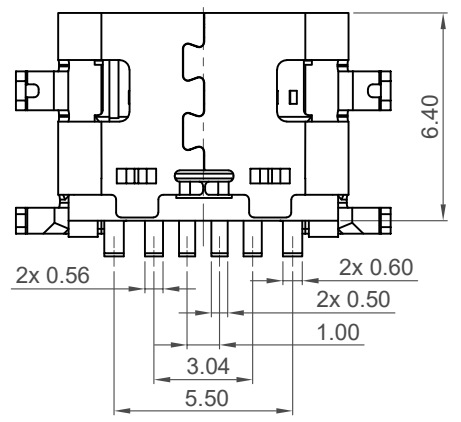
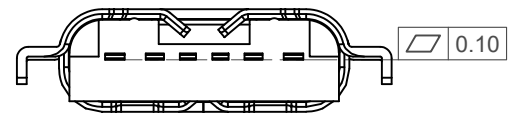
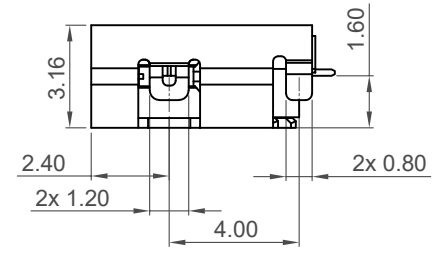
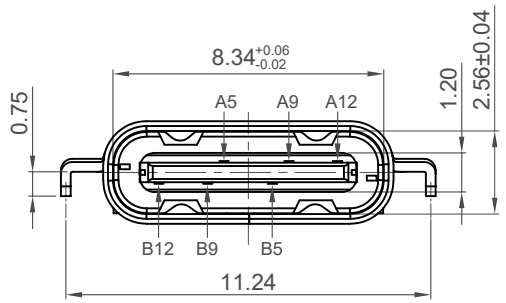

Plug and Receptacle Mating View

Ordering Grid

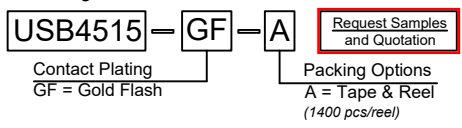

Part Number		Product Description	
USB4515		USB Type C Receptacle, SMT Type, Mid Mount, 1.6mm Offset, For Power Charging Only	
Drawing Date		1st July 2021	
By	KY	Tolerances (Except as Noted)	Units:
Detail	Drawing Release	Length	Metric (mm)
Revision	A2	Angle	
Date	23/12/24	X.X ± 0.30	
		X.XX ± 0.20	
		X.XXX ± 0.10	



This drawing is confidential and copyright of Global Connector Technology, Ltd (GCT). This drawing must not be copied or disclosed without written consent. E & OE



Not to Scale	Drawn By CC	Sheet No. 1/2
--------------	-------------	---------------

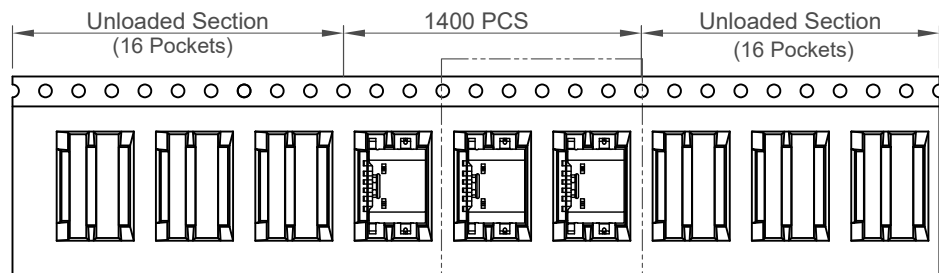

Direction of Unreeling

Detail E

Peeling Angle 165°~180°

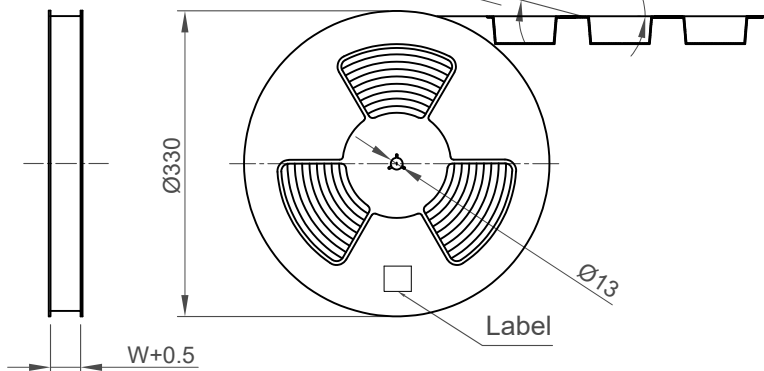

Direction of Unreeling

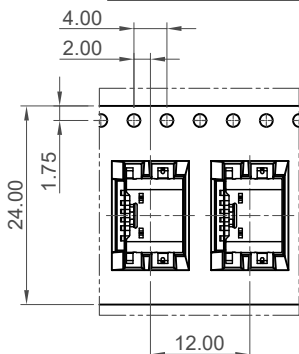

Detail: E

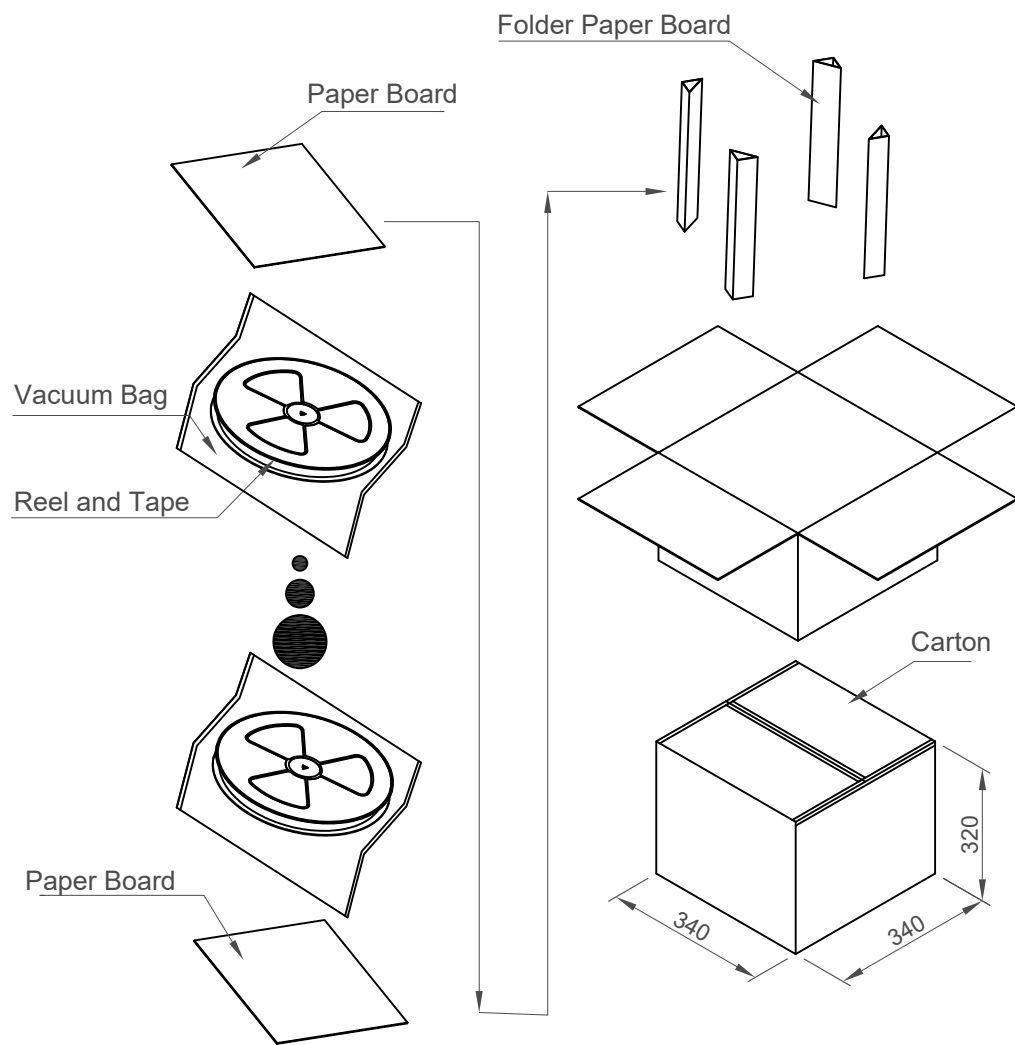

Pcs / Reel	Reels / Carton	Total Quantity
1400	10	14000 pcs

Part Number		Product Description	
USB4515		USB Type C Receptacle, SMT Type, Mid Mount, 1.6mm Offset, For Power Charging Only	
Drawing Date		1st July 2021	
By	KY	Tolerances (Except as Noted)	Units:
Detail	Drawing Release	Length	Metric (mm)
Revision	A2	Angle	3rd Angle Projection
Date	23/12/24		



This drawing is confidential and copyright of Global Connector Technology, Ltd (GCT). This drawing must not be copied or disclosed without written consent. E & OE



Not to Scale	Drawn By CC	Sheet No. 2/2
--------------	-------------	---------------